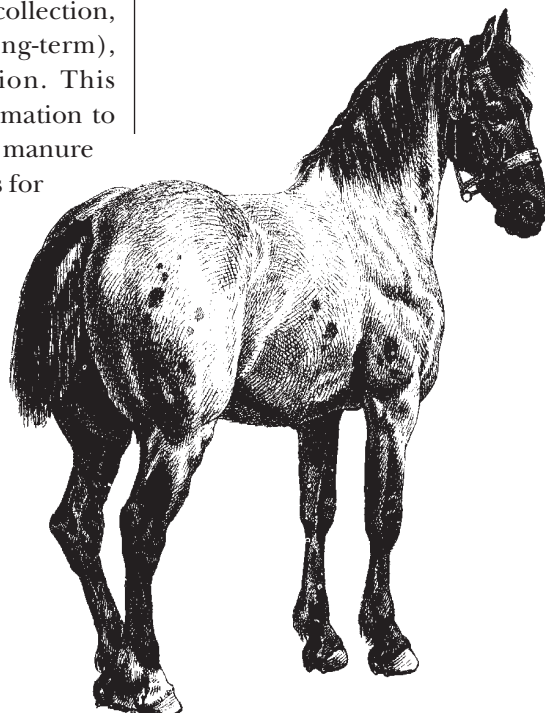


# Horse Stable Manure Management

**M**anure handling is a necessary evil of stable management with horse owners naturally preferring to ride rather than clean stalls. Making sure that stall cleaning and other manure handling chores are done efficiently can lead to more time spent with the horse. It is important to recognize that horses produce large amounts of manure that quickly accumulates! About 12 tons of manure and soiled bedding will be removed annually from each horse stall (housing a full-time occupant). Careful consideration of how this material is moved and stored is needed for efficient manure management. Getting the manure out of a stall is only the beginning. A complete manure management system involves collection, storage (temporary or long-term), and disposal or utilization. This publication provides information to stable managers on horse manure characteristics and options for its movement and storage. Associated issues such as odor control, fly breeding, and environmental impact are addressed in relation to horse facilities.

Manure management practices within horse facilities deserve careful attention. Since most

horses are kept in suburban or rural residential settings, it is essential for horse owners to be good neighbors. Often, suburban horse facilities have limited or no acreage for disposal of manure and soiled bedding. Several alternatives for handling manure include land disposal, stockpiling for future handling, removal from stable site, and composting. Some stables have developed markets to distribute or sell the stall waste. Whether in a suburban or rural setting, proper manure management is based on simple principles that will virtually eliminate environmental pollution impacts and nuisances such as odor and flies.



## Contents

<b>Stall Waste Production and Characteristics .....</b>	<b>2</b>
<b>Environmental Impact .....</b>	<b>3</b>
<b>Minimizing Nuisances.....</b>	<b>3</b>
<b>Preventing Water Pollution .....</b>	<b>4</b>
<b>Manure Handling .....</b>	<b>6</b>
<b>Manure Storage .....</b>	<b>7</b>
<b>Construction of the Manure Storage .....</b>	<b>8</b>
<b>Siting the Manure Storage.....</b>	<b>9</b>
<b>Management of the Stored Manure.....</b>	<b>11</b>
<b>Vegetated Filter Area .....</b>	<b>11</b>
<b>Manure Disposal.....</b>	<b>12</b>
<b>Other Stable Wastes .....</b>	<b>14</b>
<b>Keeping It Legal .....</b>	<b>14</b>
<b>Have a Plan .....</b>	<b>14</b>
<b>Summary.....</b>	<b>15</b>
<b>Additional Resources .....</b>	<b>15</b>
<b>Acknowledgments.....</b>	<b>15</b>



## Stall Waste Production and Characteristics

Manure includes both the solid and liquid portions of waste. Horse manure is about 60 percent solids and 40 percent urine. On average, a horse produces 0.5 ounce of feces and 0.3 fluid ounce of urine per pound of body weight every day. A 1,000-pound horse produces about 31 pounds of feces and 2.4 gallons of urine daily, which totals around 51 pounds of total raw waste per day (Figure 1).

Soiled bedding removed with the manure during stall cleaning may account for another 8 to 15 pounds per day of waste. The volume of soiled bedding removed equals almost twice the volume of manure removed but varies widely depending on management practices. So for each stall,

about 60 to 70 pounds of total waste material is removed daily. This results in about 12 tons of waste a year per stall with 8.5 tons being manure from a 1,000-pound horse.

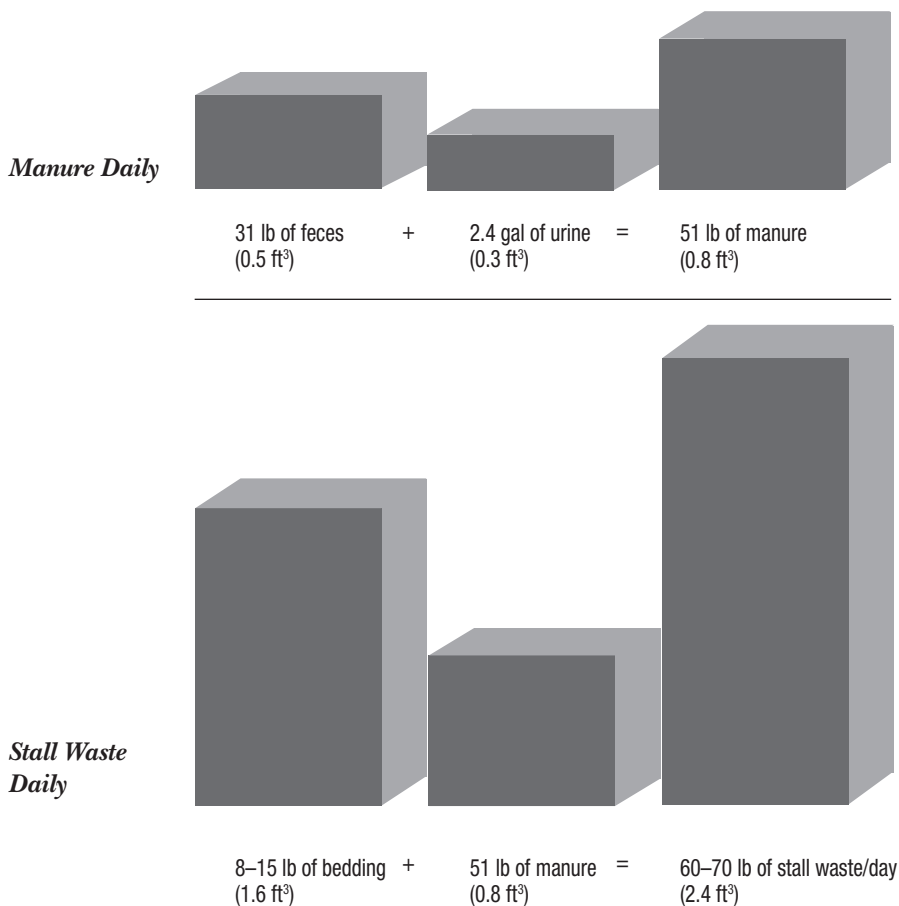
The density of horse manure is about 63 pounds per cubic foot (lb/ft<sup>3</sup>). Therefore, 51 pounds of manure would occupy about 0.81 cubic feet. The soiled stall bedding removed with this manure would be about twice this volume, so the total volume of stall waste removed per day per 1,000-pound horse may be estimated as 2.4 ft<sup>3</sup>. To put all these numbers in perspective, annual stall waste from one horse would fill its 12-foot by 12-foot stall about 6 feet deep (assuming no settling). Plan now for handling this material!

Barn chores include a daily clean-out of manure and soiled bedding,

leading to a steady stream of waste to handle. There are several common stall bedding materials and each has different characteristics in handling, field application, suitability to composting, and acceptance for sales. Availability and cost of bedding materials in the stable area will probably have the greatest influence on bedding selection (Tables 1 and 2).

The manure management needs of pastured horses are different from those of stabled horses. The field-deposited manure is beneficial because it serves as a fertilizer. Substantial amounts of manure can accumulate where horses congregate around gates, waterers, favorite shade areas, feeders, and shelters. These areas should be cleaned weekly for better pasture management, parasite control, and to diminish fly breeding.

**Figure 1. Daily manure and stall waste production from a typical 1,000-pound horse.**



**Table 1. Approximate water absorption of dry bedding materials (typically 10 percent moisture).**

[Reproduced with permission from *Livestock Waste Facilities Handbook*, MWPS-18.]

Material	Pounds of water absorbed per pound of bedding
Wheat straw	2.2
Hay—chopped, mature	3.0
Tanning bark	4.0
Fine bark	2.5
Pine chips	3.0
Pine sawdust	2.5
Pine shavings	2.0
Hardwood chips, shavings, sawdust*	1.5
Corn shredded stover	2.5
Corn cobs, ground	2.1

Not recommended for horse stall bedding: flax straw, oat straw, black cherry, and walnut wood products. The horse may eat oat straw.

\*Walnut shavings cause founder, so all hardwood shavings should be avoided on the chance that some walnut shavings could be mixed in.

**Table 2. Hay and bedding material density.**

[Reproduced with permission from *Livestock Waste Facilities Handbook*, MWPS-18.]

Form	Material	Density (lb/ft <sup>3</sup> )
Loose	Alfalfa	4
	Non-legume hay	4
	Straw	2–3
	Shavings	9
	Sand	105
Baled	Alfalfa	8
	Non-legume hay	7
	Straw	5
	Wood shavings	20
Chopped	Alfalfa	6
	Non-legume hay	6
	Straw	7

Manure collected from paddocks and pastures may be added to the stall waste stockpile.

Horse manure has been considered a valuable resource rather than a “waste.” Fertilizer value of the 8.5 tons of manure produced annually by a 1,000-pound horse is about 102 pounds of nitrogen (N), 43 pounds of P<sub>2</sub>O<sub>5</sub> (phosphorus pentoxide [phosphate] = 43.7 percent P), and 77 pounds of K<sub>2</sub>O (potash = 83 percent K). The nutrient content of horse manure can also be represented as 12 lb/ton of N, 5 lb/ton of P<sub>2</sub>O<sub>5</sub>, and 9 lb/ton of K<sub>2</sub>O (nutrient values for any manure vary widely, so these are only guidelines). Traditionally, nitrate-nitrogen is the component that presents the most pollution potential since it moves freely in the soil. Most of horse manure’s nitrogen is contained in the urine.

These values are an average for horse manure (urine and feces). With the large amount of bedding material mixed with manure in typical stall waste, the fertilizer nutrient value would vary (see Direct Disposal section on page 12).



## Environmental Impact

### Minimizing Nuisances

For a suburban setting, one potential problem includes overcoming misconceptions about the nuisance and pollution potential of horse facilities. Most people enjoy horses, yet neighbors can be more concerned that horses are manure-generating, fly and odor machines. A horse facility operating with a large number of horses on limited acreage can intensify nuisance problems not noticed at small stables. Generally in the Northeast, 2 to 3 acres of good pasture per horse is needed for summer feeding purposes. More horses per acre are common and successfully managed with supplemental feeding. Fortunately, careful management and attention to detail can overcome potential problems of intensive horse operations.

Pests commonly associated with animal agriculture are flies and small rodents, such as mice and rats. Flies and odors are the most common complaints, but proper manure management can virtually eliminate farm pests and odors. Figure 2 shows some simple yet important site-planning features to minimize nuisances associated with manure management.

**Insects.** It is always easier and more effective to prevent fly breeding than it is to control adult flies. Eliminating the habitat required by the larvae to hatch and grow significantly reduces fly populations. Because flies deposit eggs in the top few inches of moist manure, minimizing moist manure surface area is one reduction strategy. Eggs can hatch in as little as 7 days under optimal temperature and moisture conditions. Fly breeding season starts when spring temperatures get above 65°F and ends at the first killing frost in the fall. Under ideal breeding conditions, it



has been calculated that one fly can produce 300 million offspring in about 60 days! Few flies will develop if manure is removed from the stable site or made undesirable for fly breeding within a maximum 7-day cycle.

Keep manure as dry as possible, below 50 percent moisture, to make it less desirable for egg deposition. Spread manure out in thin layers during field application or field dragging, or keep out precipitation by roofing or tarping the permanent holding area and covering any dumpsters or temporary manure storage. Cleaning up decaying organic material is essential to fly control. Filth flies lay eggs in any decaying organic matter, including spilled feed, manure left in stall corners, grass clippings, and manure piles. Store small amounts of manure in containers with tight-fitting lids. Cleaning up spilled grain will not only suppress filth fly populations but will also reduce feed sources for mice and rats. Further information is available in *Pest Management Recommendation for Horses* (see Additional Resources).

**Rodents.** Clean out trash, dumps, piles of old lumber or manure, and garbage where rats and mice hide. Keep weeds trimmed around buildings to reduce hiding places. Stacked feedbags create ideal passageways in which rodents can eat, hide, and breed. Store feed in rodent-proof bins, preferably metal or lined with metal or wire mesh. A 30-gallon trash can will hold a 100-pound sack of feed. Feed from these containers rather than from an open bag, and clean up any spills immediately. Areas under feed bins, bunks, and buckets are excellent feeding grounds for rodents. Concrete floors and foun-



dations deter rodent entry as do metal shields on doors and screens over small openings. Young mice can squeeze through an opening as small as ¼ inch. Overfed, pet cats are not usually good mousers, but a barn cat can deter rodents. Poison bait is not often safe around horse facilities due to the presence of pets and children; however, secure bait boxes are effective.

**Odor.** Nuisance odor from the horses themselves is generally minimal. Offensive odors can be generated from manure. If manure is allowed to decompose without enough oxygen, it will be anaerobic (without oxygen) and will usually produce offensive odors. Aerobic (with oxygen) decomposition, such as composting, does not produce such odors because the microbes decomposing the waste use the nutrients and produce odor-free compounds (water vapor and carbon dioxide, for example) as a byproduct. Anticipate some odor from the manure storage area since fresh manure is added daily. Place the area downwind of the stable facility and residential areas to minimize odor problems. Summer breezes are the main concern if winter and summer prevailing wind directions are not the same. Neighbors will be less tolerant during warm weather since they are outdoors more often and have open house windows.

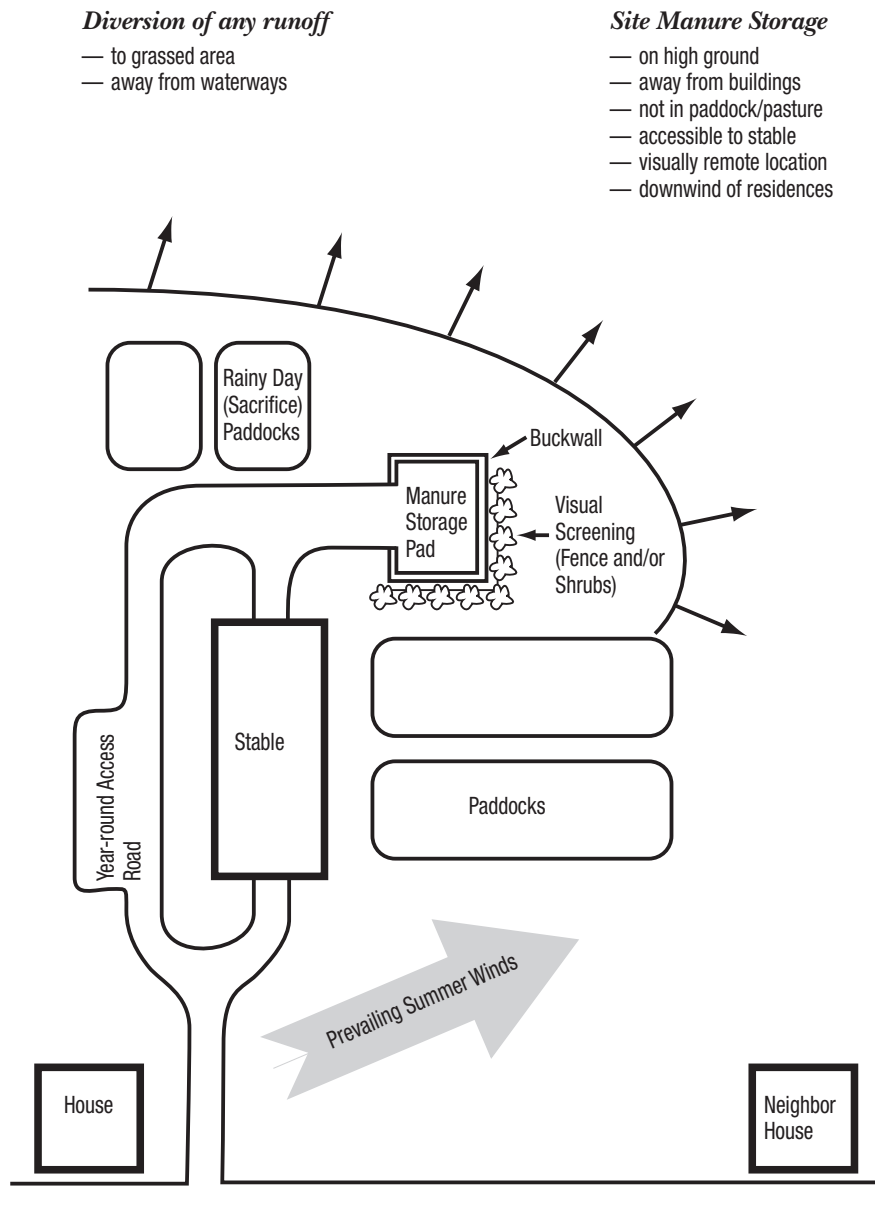
**Aesthetics.** Another nuisance associated with waste management can be the visual aspect of large manure storage piles. Keep the storage site screened from view with vegetation, fencing, and/or by location in a remote area. A well-designed and managed stall waste facility can be reasonably contained and not offensive visually. Screening the storage site is worthwhile because “out of sight is out of mind,” if the storage is otherwise well managed.

## *Preventing Water Pollution*

**Manure pile runoff.** Any on-site manure storage should not contribute to groundwater or surface water pollution. Leachate is the brownish liquid that has “leached” from the solid pile contents and drains off a waste pile bottom. Not all piles will have leachate; in fact, proper management can avoid leachate formation. Stall waste is typically very dry with little leachate. When water or pure manure, such as from paddock or arena cleanup, is added, some leachate may form. A covered storage area will have much less leachate than one exposed to precipitation. Prevent any pile leachate from contaminating groundwater or nearby waterways by capturing or diverting it. A concrete pad with sidewalls is necessary to contain leachate from very large, uncovered piles. Leachate drainage to a treatment system such as a grassed infiltration area (see Vegetated Filter Area sidebar on page 11) is necessary to prevent runoff to geologically and socially sensitive areas. Another potential source of water pollution is from field-applied manure that is subject to surface runoff conditions or deposited near waterways. Apply stall manure so runoff is minimized; guidelines are provided in the Direct Disposal section on page 12.

**Stall flooring.** The type of stall flooring may determine the potential for groundwater pollution from the stable. Concrete, most asphalt, and well-packed clay floors are considered impermeable to water flow. However, with any stall flooring material, there is so much bedding used in horse stalls that urine and any liquid from the manure are soaked up by bedding. Therefore, free urine in contact with the flooring material is minimized compared to other livestock housing. Drains are not necessary in horse stall floors, except under circumstances noted below.

**Figure 2. Farm plan showing manure management for minimizing nuisances.**



Wash stalls should have impermeable and durable floors such as concrete or asphalt. Drains are recommended for wastewater removal to an approved discharge area (see Vegetated Filter Area sidebar on page 11). Some stalls are frequently washed down and disinfected, such as foaling stalls or hospital stalls. When large amounts of water are used, impervious floors and drains are necessary.

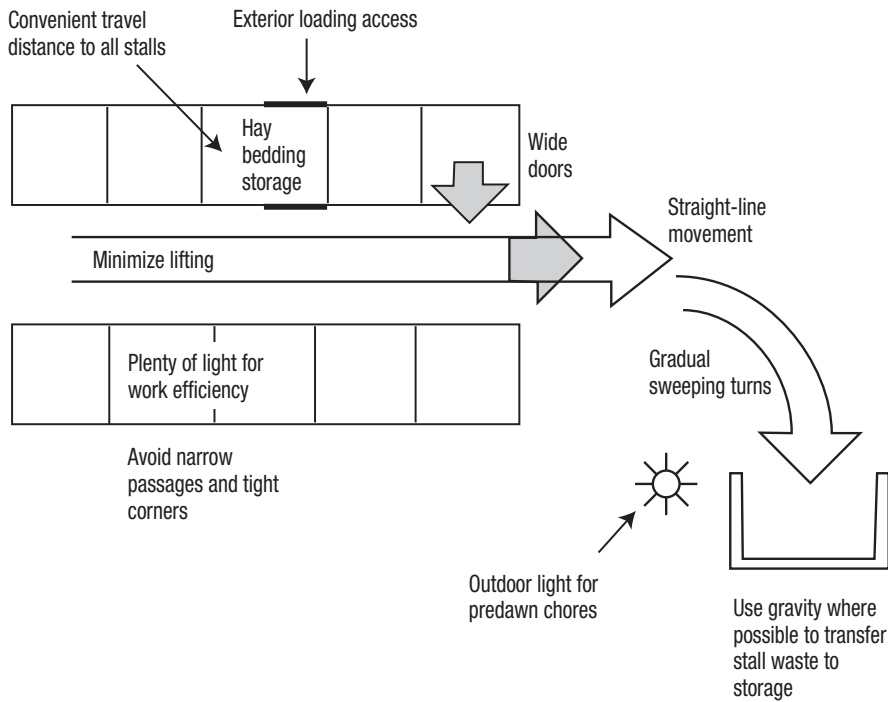
Drains in the stall should be outfitted with a removable cover and located on one side of the stall to prevent discomfort when the horse lies down in the center of the stall. The floor should slope slightly (1 inch per 6 feet is adequate) toward the drain. An alternative is to slope the stall floor toward the front stall door where a shallow, narrow gutter (about 1 inch deep by 4 to 12 inches wide) is

positioned along the front stall wall in the aisle floor. This gutter would then slope along the aisle toward drains. See "Horse Facilities 4: Horse Stable Flooring Materials and Drainage" for more information.

The floor in an open-sided shed usually consists of the native material found on the building site. Pastured horses do not spend much time in the shelter unless encouraged to do so by feeding or fencing. Groundwater pollution is minimal because little manure is deposited in the shed. If horses are fed or confined in this facility, then a more durable floor may be desirable along with a plan to collect and dispose of the accumulated manure. Packed limestone screenings work very well in open sheds by providing good drainage and ease of cleaning.

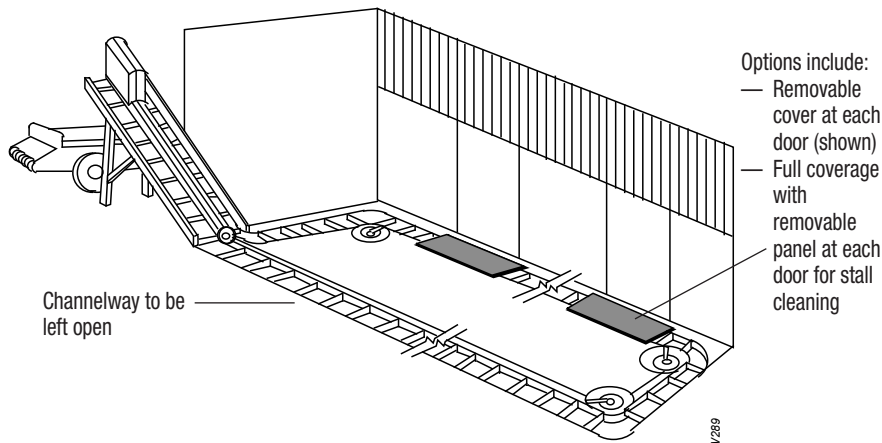
**Rainy-day paddocks.** Many farm managers have rainy-day paddocks that are exercise lots with no pasture grass. They are used for turnout during inclement weather when horse traffic on grass pastures would tear the turf into a muddy mess. Ungrassed paddocks also work well for horses kept on limited acreage or when pastures are reseeded, fertilized, or rested as part of rotational grazing program. Some managers use outdoor riding arenas for turnout paddocks. Locate exercise paddocks on high ground with provision for cleaning the area of manure and decreasing runoff potential (Figure 2). A stone dust footing works well by decreasing mud, aiding drainage, and providing a surface to collect manure. The rainy-day paddock should be surrounded by well-established sod so that any runoff is captured and diverted from adjoining buildings and pastures. Fence sensitive areas around streams and natural waterways to alleviate further water pollution.

**Figure 3. Efficient handling of large quantities of bulky material includes straight-line movement through wide doors to a convenient stockpile area.**



**Figure 4. Automated barn cleaner.**

Adapted from *Livestock Waste Facilities Handbook*.



## Manure Handling

**Efficient movement.** When handling large quantities of bulky material, straight-line movement through wide doors is the most efficient. Avoid stable designs that necessitate turns and tight passages for travel from the stall to manure deposition area. Hand labor is most common in horse stall cleaning. To increase worker efficiency, provide plenty of stall light, minimize lifting, and make the temporary manure stockpile area easily accessible from all areas of the stable (Figure 3).

In most stables, stalls are cleaned daily and manure temporarily stockpiled in an accessible area near the barn. To avoid additional handling, workers can temporarily stockpile manure in a vehicle, such as a manure dumpster or spreader. Once the stall cleaning chores are finished or the temporary storage is filled, the stockpile is moved to the long-term storage location or removed from the stable site.

**Mechanization** can replace some hand labor of stall cleaning. A common adaptation is a motorized vehicle pulling a cart through the working aisle of the stable. The engine exhaust and the repositioning of the cart can detract from its ultimate usefulness and become a health hazard if the stable is inadequately ventilated. The cart can efficiently transport material to areas more remote from the stable.

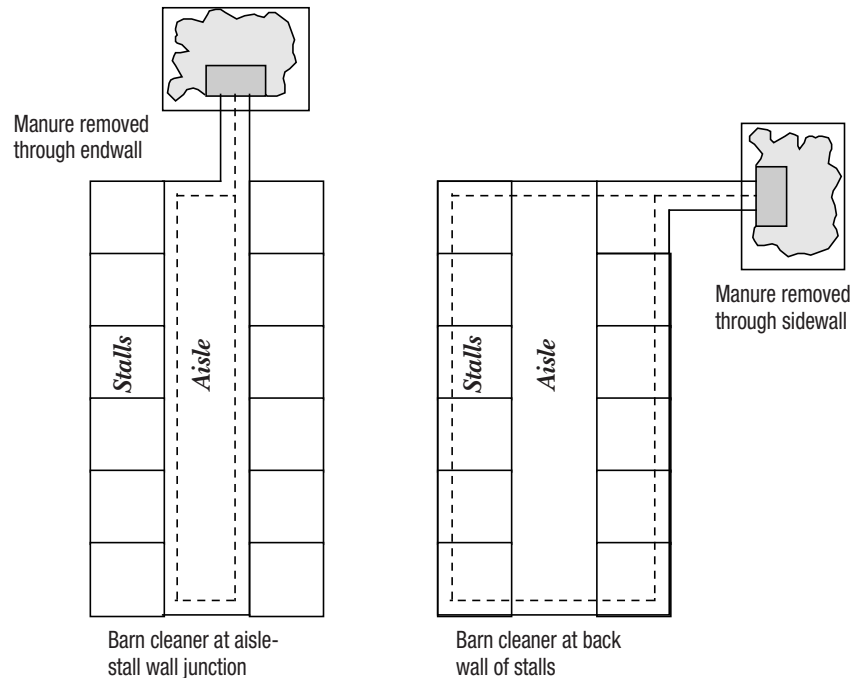
A mechanized alternative is the barn cleaner, which automatically moves the waste from the stall area to the temporary stockpile area. A barn cleaner is a scraper that operates in a narrow gutter (about 16 inches wide) and has closely spaced flights on a chain drive (Figure 4). It is designed to handle wastes with high solids content typical of horse stall waste. The gutter cleaner can be located under the floor at the back of the stall or

along the side of an aisle servicing the stalls (Figure 5). The primary advantage is that minimal worker effort is required to move stall waste into the gutter: no lifting, no moving carts, and no travel to the temporary stockpile area. The disadvantages are the initial cost, complex installation, and maintenance of the gutter system. Stall gutters must be covered and bedded over when horses are in the stall. With aisle gutters, horses get used to stepping around them even if gutters are left uncovered. Safety may become an issue if normally covered aisle gutters are left open.

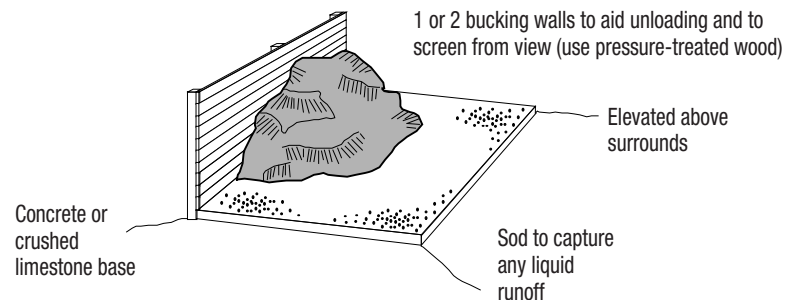
## Manure Storage

The stall waste will have to be stored somewhere whether temporarily or long term. Keep stored manure in a fly-tight area during the warm months or manage to prevent fly breeding and protect from rainfall and surface runoff. A well-built storage pad or container aids in waste handling and minimizes pollution potential from the pile. The pad can be as informal as a level, well-packed surface with a wood or masonry backstop (Figures 6, 7, 8) or a covered structure with impermeable flooring. If topography permits, a below-grade storage container is a less objectionable structure as it keeps the manure contained to a small area, is out of view, can be covered, and is easily filled using gravity to dump waste into it (Figure 9). One side should be at ground level for emptying. Longer-term manure storages are often more substantial structures than short-term storages. Large quantities of manure require a storage designed with wide door(s), a high roof, and strong construction to allow cleanout with power equipment. Construction features are shown in Figure 10. Additional details of large manure storages are available in the *Livestock Waste Facilities Handbook* (see Additional

**Figure 5. Options for automatic barn cleaner gutter and stockpile placements.**

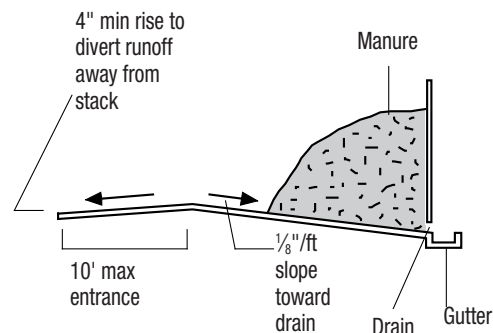


**Figure 6. Simple manure stockpile pad with backstop, which is suitable for a small stable. Use a tarp or other cover to minimize leachate production from precipitation.**



**Figure 7. Manure pad slope and drainage. Drain and gutter are recommended in all cases, especially if the manure stack will not be protected from rainfall. Leachate (effluent) must be directed to a storage tank and/or suitable method of disposal.**

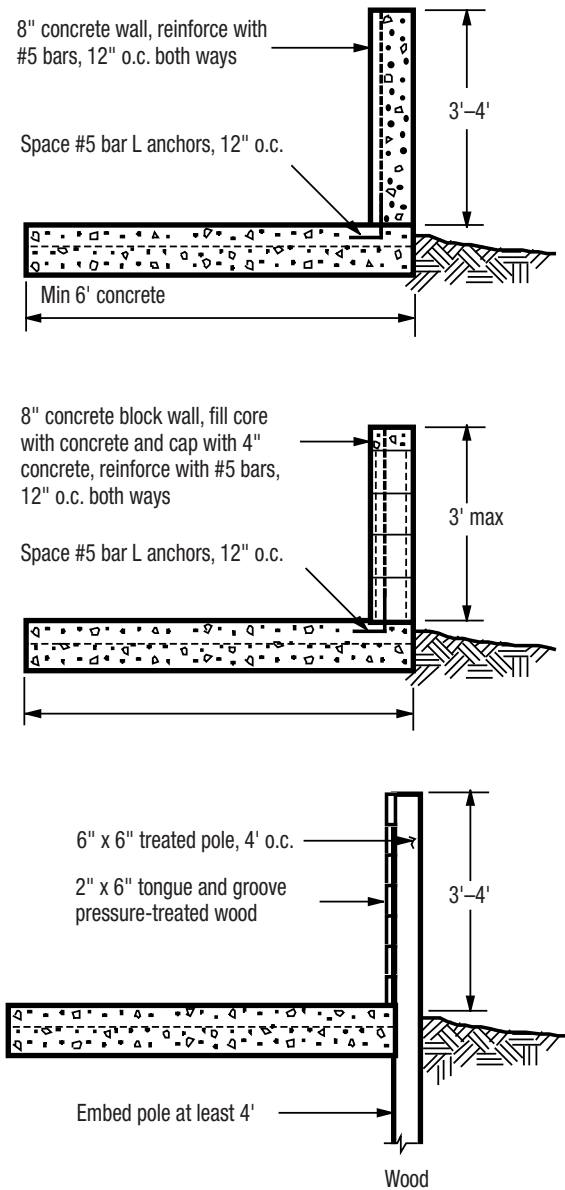
Reproduced with permission from *Livestock Waste Facilities Handbook*, MWPS-18.



**Figure 8. Bucking wall options.**

Note: These drawings are general representations and are not meant as construction drawings. A site-specific design is recommended in all cases. If soil backfill is to be placed behind the wall, a more economical wall may be possible.

Adapted from *Livestock Waste Facilities Handbook*, MWPS-18.



**Table 3. Minimum separation distances commonly recommended for composting and manure-handling activities.**

Source *On-Farm Composting Handbook*, NRAES-54.

<i>Sensitive area</i>	<i>Minimum separation distance (feet)</i>
Property line	50–100
Residence or place of business	200–500
Private well or other potable water source	100–200
Wetlands or surface water (streams, pond, lakes)	100–200
Subsurface drainage pipe or drainage ditch discharging to a natural water course	25
Water table (seasonal high)	2–5
Bedrock	2–5

Resources). Manure for commercial pick-up can be stored in a container or dumpster. With any large or small manure storage, a tarp or other cover is recommended to minimize leachate production from rainfall.

**Construction of the Manure Storage**

Size the storage for about 180 days of long-term storage in cold climates. This provides winter storage when fields are not accessible and for summer when crops may be present. An estimated waste production of 2.4 ft<sup>3</sup> per day per horse would require 432 ft<sup>3</sup> of storage for each stalled horse. Base sizing figures on estimates that reflect the specific stable’s management. It is better to have a slightly larger storage facility than one that is too small. Whether constructing a simple manure pad or more formal storage structure, some common practices will minimize labor and make nuisance control easier.

Slope entrance ramps upward with a minimum 10:1 slope (Figure 7) to keep out surface water. Provide a rough-surfaced load-out ramp at least 40-feet wide if commercial-sized



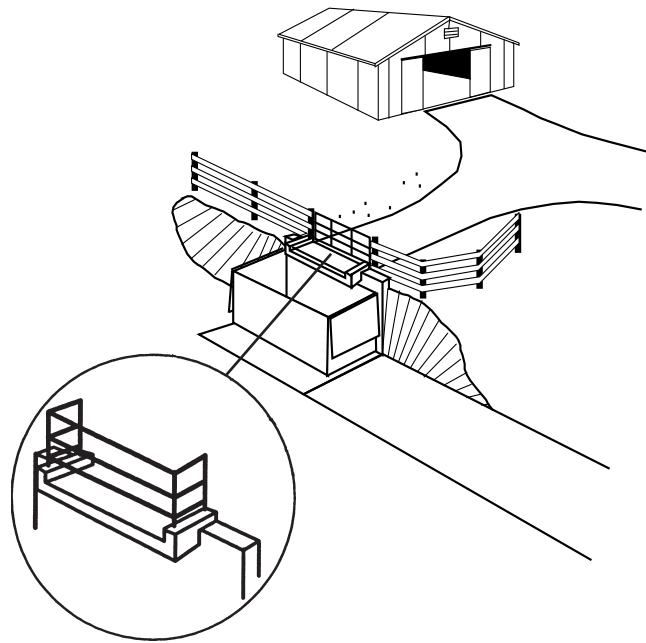
agricultural machinery will be used to load and unload the storage. A smaller width of 20 feet is acceptable for smaller farm and garden tractors, leaving enough room to maneuver the tractor during unloading. Angle grooves across the ramp to drain rainwater. Install a 4-inch-thick concrete floor and ramp over 6 inches of coarse gravel or crushed rock (up to 1.5 inch aggregate size). Two inches of sand can replace gravel as fill under the concrete when placed over undisturbed or compacted soil. Smaller or private stables can suffice with well-packed stone dust. Bucking walls (backstop) are recommended to aid in unloading; options are provided in Figure 8.

If liquids such as unabsorbed urine, snowmelt, and rain are to be stored, slope the floor toward a closed end. The floor may be sloped to one or both sides, with openings on the low side to a gutter or surface drain (Figure 11). Unabsorbed liquids may be diverted to a gently sloped, grassed area that acts as a vegetated filter (Figure 12). Additional problems of handling separated liquids may make use of roofs or extra bedding a better solution. A large, unroofed storage (such as those serving multiple stables at a track) may need floor drains connected to underground corrosion-resistant 8-inch pipes to carry away liquids. Provide removable grills for periodic cleaning, or start the stack with 6 inches of absorbent material such as wood or bark chips to absorb some liquids and permit drainage.

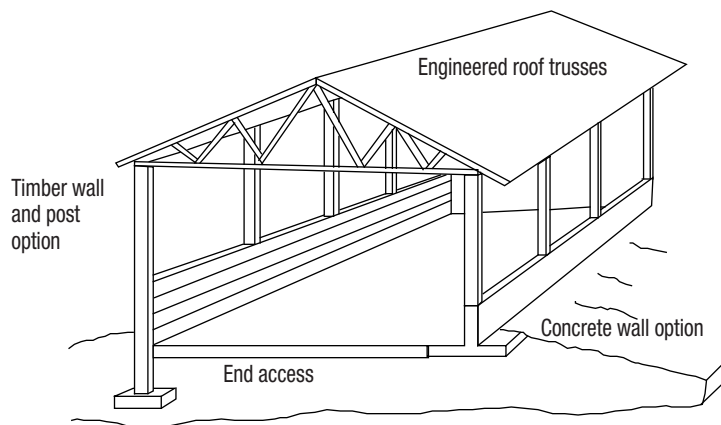
### *Siting the Manure Storage*

The waste stockpile areas must be accessible to trucks or tractors in all weather conditions. A location on high ground will usually provide firm soil well above groundwater, forming a suitable base for the storage facility and access road. Keep manure away from building materials, as corrosive chemicals in the manure can damage

**Figure 9. Manure storage container uses topography and gravity for ease of waste-handling chores. Two options are shown for manure drop-off protection.**



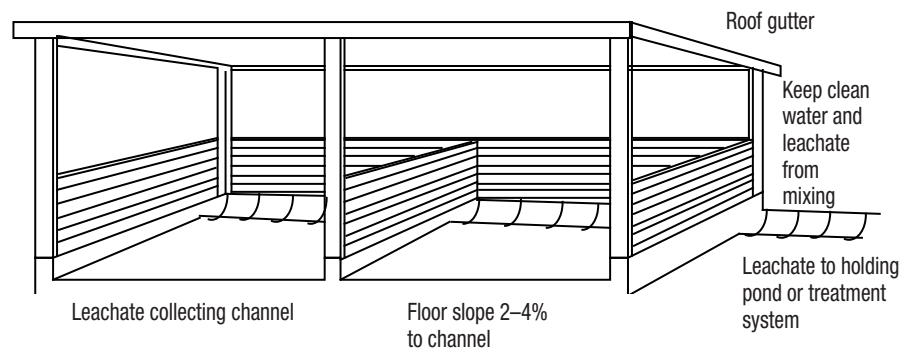
**Figure 10. Features of large, roofed, solid-manure storage.**



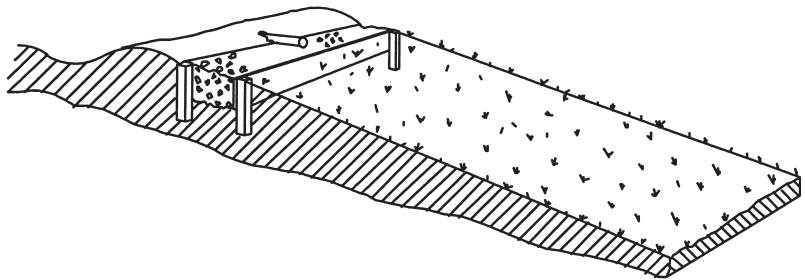
them. Do not store manure where runoff or floodwater will cause nutrients to enter nearby waterways. Table 3 lists distances to separate the manure storage from sensitive areas such as nearby water sources or residences. Do not store manure in paddocks due to increased parasite exposure for the horses. Locate storages downwind from both the farm and neighbors' residences. Consider the aesthetics of the storage placement so that it can be screened from view (See Figure 2). Use natural or humanmade screening such as a hedgerow or fence to improve the aesthetics and help contain any odors. Remember that for many perceived nuisances, out of sight can be out of mind for neighbors. Provide for easy filling of the storage with a tractor-mounted manure loader or scraper elevator stacker unit. Unload waste with a tractor-mounted bucket.

Good drainage at any manure storage site is absolutely necessary. The site may be graded to divert surface runoff without creating erosion. Poor drainage results in saturated conditions, leading to muddy access and pools of dirty water. Divert any surface drainage water and runoff from nearby roofs away from the pile area. *On-Farm Composting Handbook* (NRAES-54) has details of surface water diversion and site grading. Many stables and indoor riding arenas do not have gutters and downspouts, causing substantial runoff from these buildings. A gutter and downspout system will collect and divert water away from the building foundation and bypass the manure storage. Tarps or a roof over the manure storage can minimize rainwater entry if leachate containment becomes a problem. Do not allow polluted runoff to pool, as mosquitoes and flies will breed in the moist area.

**Figure 11. Covered storage with leachate collection for wet materials.**



**Figure 12. Grassed filter area for treating manure storage leachate. Use a site-specific design of the vegetated filter based on leachate production and site characteristics.**





### *Management of the Stored Manure*

With proper management, flies and odors from manure storage can be minimal. The major deterrent to fly breeding in horse operations is to keep the manure as dry as possible. Other wet organic material sites also need to be removed. Remove manure from the farm at least every 7 days during fly breeding season or operate a properly managed composting facility.

Add new stall waste to the pile as a large block of material to minimize fresh manure surface exposure. This reduces the area of odor volatilization and access to moist manure for fly breeding. Avoid dumping new material on top of a pile where it spreads out and falls away down the sides, creating a large fresh, wet manure surface area that promotes flies and odor. Flies lay eggs in the top 2 inches of moist manure.

Naturally occurring fly predators, tiny, non-stinging wasps and parasites, are beneficial to the manure storage. Avoid indiscriminate use of larvicides and other pesticides that kill predator wasps and parasites. Depending on the species, wasps have 10- to 28-day egg and larva stages. Wasps are active during fly season (some are killed by cold temperatures), and their activ-

ity depends on manure conditions, with dry manure best. Wet manure decreases wasp effectiveness.

When cleaning out the storage, leave a 4-inch *dry* pad of manure over the bottom of the storage area to provide a stock of fly parasites and predators. Manure removal can be staggered to leave one section per week to supply fly predators and parasites. Remove a winter's stockpile of manure during cold weather (<65°F) before fly breeding begins.

### **Vegetated Filter Area**

A grassed, gently sloped area may be used as a filter and infiltration area for wastewater (Figure 12). Wastewater is piped to the filter area and spread evenly across the top portion of the filter. As it flows through the soil profile and down the slight slope, biological activity and adsorption in the soil matrix remove waste materials. Most biological activity occurs in the topsoil layer where aerobic (using oxygen) activity provides for odor-free treatment. Obviously, not all soils are equally suitable since some provide rapid infiltration for limited treatment while others are rather impermeable and provide surface runoff. Frozen soil will not act as a proper filter. Get professional help from the Natural Resources Conservation Service or your County Conservation District, for example, for proper filter sizing and design.

Vegetated filter area is a relatively low-cost farm wastewater treatment system. They can vary in cost, approaching that of a septic system. In size, one rule of thumb is to provide about 10 square feet of vegetated filter for each gallon of wastewater being handled. The spreading device at the head of the filter strip is important for establishing even flow to minimize short-circuiting wastewater through the area. A settling tank before the filter strip will be needed if manure solids are allowed into the wastewater.

These filter areas need to be well vegetated before put to use. Keep animals off the filter strip, as the frequent wet soil conditions lead to destruction of the sod cover by horse grazing and exercise. If the storage facility will hold the manure from more than a few horses, the volume and strength of the leachate may be too great to send directly to a vegetated filter. In that case, the liquid should be collected in a tank and dosed to the vegetated filter every 3 or more days, or irrigated on pasture. In any case, a site-specific design is recommended.

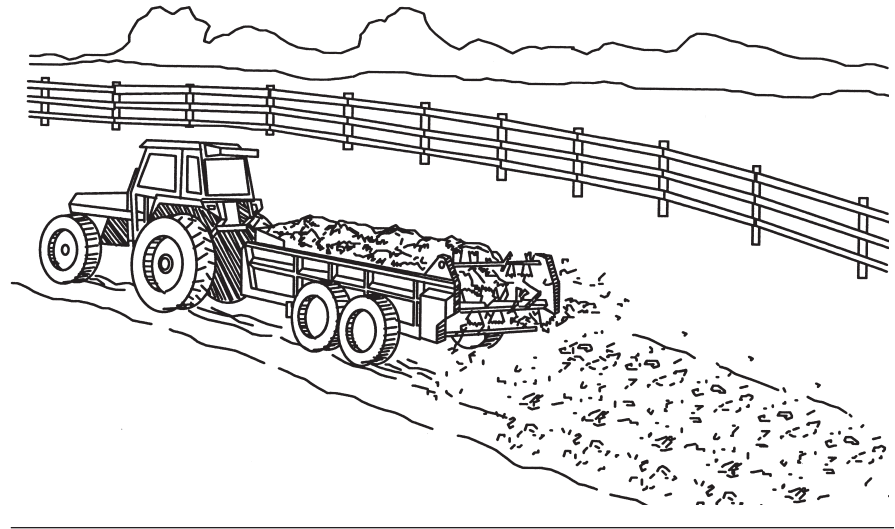
## Manure Disposal

**Direct disposal.** Direct disposal involves the on-farm use of the stall waste via field application. Proper field application demands equipment such as a tractor and spreader so that the manure is applied in a thin layer over the soil (Figure 13). The thin layer is essential for drying the manure to discourage fly breeding and also spreads the nutrients for more optimal plant use. Weekly spreading in the summer will disrupt fly breeding and egg development cycles. To minimize pollution from runoff, do not spread manure on frozen ground or near waterways. It may not be possible to spread manure each week year-round, in which case the manure must be stockpiled. In cold climates, figure on 180 days of stockpile storage space. Manure application may be limited to preplanting and post-harvest dates for cultivated fields. Fields may not be accessible due to heavy snow accumulation or soil that is too wet to support equipment traffic.

Spreading manure in thin layers has been thought to reduce parasite numbers by desiccating the eggs. This does hold true under dry and extreme cold or hot conditions. Under the moist conditions encountered in the northeastern United States, the practice of spreading manure in thin layers on pasture is being questioned (as far as parasite control is concerned; the other nutrient, aesthetic, and fly egg desiccation characteristics remain). Recent evidence suggests that spreading thin layers of manure on pastures can enhance grazing horses' parasite exposure by spreading viable parasites over a larger area. The recommendation is to leave the manure piles in clumps and pick them up for disposal outside the pasture area.

**Figure 13. Proper application with a tractor and spreader provides a thin layer of stable waste over the soil to improve manure drying and fertilizer application along with decreased fly breeding.**

Adapted from *On-Farm Composting Handbook*, NRAES-54.

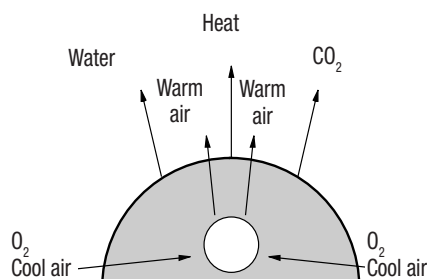


Field application is based on fertilizer needs of the crop or pasture grass through soil sampling. The approximate fertilizer value of manure from bedded horse stalls (46 percent dry matter) is 4 lb/ton ammonium-N, 14 lb/ton Total N, 4 lb/ton  $P_2O_5$  (phosphate), and 14 lb/ton  $K_2O$  (potash). Fertilizer value of manure at 20 percent moisture without bedding is approximately 12-5-9 lb/ton (N- $P_2O_5$ - $K_2O$ ). Nutrient values vary widely, so use these values as guidelines and have the manure analyzed if more specific data are needed. The amount of organic nitrogen mineralized (released to crops) during the first cropping season after application of horse manure is about 0.20. Organic nitrogen must be released through mineralization before plants can use it. About 20 percent of the organic N from horse manure is available to the pasture grass the year of application. Organic N released during subsequent seasons is usually about 50 percent (second year), 25 percent (third year), and 13 percent (fourth year) of the first year mineralization.

**Contract disposal.** Another manure disposal option is to contract with a hauler who will remove the waste from the stable facility. The waste can be used in a commercial composting operation or for other functions where the waste disposal is the responsibility of the hauler. Dumpsters are positioned at the stable for temporary stall waste storage (no trash or garbage); a full dumpster is replaced with an empty one. Dumpsters should be sized so that the contents are emptied at least weekly during the fly-breeding season. Place the dumpster in a convenient location where barn waste can be dumped into it and trucks can access and empty the dumpster during all weather (Figure 9). A concrete tank or pad is useful to contain any dumpster leachate.

A less formal "contract" disposal is to interest neighbors in free garden organic material. The key is to locate the organic fertilizer enthusiasts. Owners of small stables have had success with newspaper ads and locating "free" bagged manure at curbside.

**Figure 14. Simple process of a composting stall waste pile.**

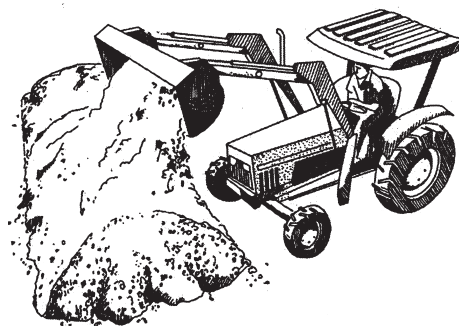


Empty feed sacks filled with horse manure are a useful package for manure distribution.

**By-product: compost.** An alternative to “disposing” of horse manure is to compost it into a by-product of the operation. Composting occurs naturally if stall waste decomposes in the presence of oxygen and is kept relatively moist, above 50 percent moisture content (Figure 14). The microbes that decompose the bedding and manure occur naturally in stall waste. In fact, commercial composters and mushroom substrate preparation facilities often seek straw-bedded horse stall waste. Composting provides a material that is more readily marketable than raw stall waste. Finished compost is partially degraded manure, which is more organically stable, presenting less of a pollution threat. Its finer texture, high organic matter content, and fertilizer value make it desirable as a garden soil amendment. Composting reduces the volume of waste by 40 percent to 70 percent. Horse manure, with its associated bedding, is almost perfectly suited for composting because it has appropriate levels of nitrogenous material and carbon-based bedding material. (The carbon:nitrogen ratio of stall waste is 20:1 to 30:1.) Stables have successfully given away, or even sold, bulk and bagged horse compost.

**Figure 15. A front-end loader (pictured) or specialized compost-turning equipment is used to turn compost in professionally managed composting facilities.**

Reproduced with permission from *On-Farm Composting Handbook*, NRAES-54.



Golf courses and nurseries provide an outlet for truckloads of compost.

Pathogens and fly eggs are killed by composting's high temperature. Parasite eggs can be killed with a 30-minute exposure to 140°F that will occur on the inside of a properly composted pile. These temperatures are not reached on the pile exterior, which is one reason the pile is periodically mixed and turned so that exterior material is incorporated into the middle for full composting. Stall waste composts well in piles that are at least 3 feet square by 3 feet deep. Smaller piles will not retain enough heat to reach the proper composting temperature.

There is a trade-off between the complexities of composting facilities versus the amount of time to produce finished compost. For example, static pile composting, which is informally practiced at most stables, involves simply piling the stall waste and letting it “compost” for 6 months to 2 years. In contrast, with more ideal conditions and intensive management, the same stall waste could be composted in about 4 weeks. Intensive management of a composting operation entails daily monitoring and periodic (perhaps weekly) attention to mixing the raw ingredients, forming the pile, and perhaps turning the compost (Figure 15).

Compost microbes live most comfortably at certain temperatures (130–140°F) and moisture levels (50–60 percent). They need oxygen (5–15 percent), so waste pile aeration is necessary. The more carefully these biological factors are controlled, the more sophisticated the compost facility becomes. It takes 2 weeks to 6 months to produce finished compost under professionally managed conditions. The benefit of faster production is that less space is needed for compost processing and storage. Large, commercial compost facilities provide near-ideal conditions for composting to speed the process and minimize space. A good and thorough guide called *On-Farm Composting* is available (see Additional Resources).

Intensive composting will be another daily operation at the stable. This responsibility may not be of interest to all stable managers. The sale or disposal of the compost must also be considered. Marketing and potential liability becomes important if off-farm disposal is desired. Having a ready outlet for compost will make the facility and time investment more worthwhile. With limited hauling, a centralized cooperative facility could be managed for several farms with more effective process labor and marketing of compost being additional benefits.

## Other Stable Wastes

Waste management is not confined to horse stall waste at a large facility. Keep trash separate from manure and soiled bedding for disposal. Recyclable materials are also kept separate for collection. Medical waste (e.g., syringes) usually has special disposal requirements. Fertilizers and pesticides and their containers sometimes have disposal restrictions. Human waste from a bathroom requires a septic system or connection to municipal sewer. Gray water, such as shower and sink water, may also go to the septic/sewer unless it is needed for groundskeeping or other uses where high-quality water is not necessary. A grassed filter area may be used to treat wastewater from the stable's horse wash stalls, tack area, laundry, showers, and feed room.

Drainage and surface runoff from pavement, building roofs, unvegetated paddocks, and exercise areas need to be managed. This is especially important for areas where manure is allowed to accumulate between rainfall or thawing events. Runoff should not enter natural waterways where it could increase nutrient level of the water or contribute to increased erosion. Pick up excess manure from paddocks and exercise areas and add it to the manure handling system.



## Keeping It Legal

Various state and federal regulations for protecting environmental quality are aimed at manure management. Often categories of livestock (including horse) operations are defined that relate to their potential to cause environmental harm. When stable facilities and manure storage structures are properly designed, constructed, and managed, the manure is an important and environmentally safe source of nutrients and organic matter. Proper land application of manure will not cause water quality problems. The intent of regulations is to ensure that economically practical techniques are used in all aspects of manure handling. All farms are required to properly handle manure in accordance with Pennsylvania's Clean Streams Law, and written Nutrient (Manure) Management Plans are typically required.

In Pennsylvania, all farms of any size that produce or utilize manure must manage manure application under the guidance of a Manure Management Plan or Nutrient Management Plan. To find out which plan your farm needs, you may find the article at [extension.psu.edu/have-a-horse-or-steer-in-your-backyard-you-need-a-manure-management-plan](http://extension.psu.edu/have-a-horse-or-steer-in-your-backyard-you-need-a-manure-management-plan) useful or contact your County Conservation District. Both types of management plans need information such as the amount of manure generated on the farm, the manure nutrient content, manure application rates, and handling procedures, including manure stockpiles and paddock management. A signed agreement is needed if manure is exported from the site.

The Pennsylvania Department of Environmental Protection (DEP) published an updated version of the *Land Application of Manure, Manure Management Plan Guidance* in 2011. This manual provides guidance and a workbook template for the devel-

opment of a Manure Management Plan. Most Pennsylvania equine farms would fall within the guidance of this regulation. Horse owners can download the workbook and complete the Manure Management Plan themselves. The written plan does not need official approval unless the farm is considered a high-density animal operation.

The Pennsylvania Nutrient Management Act is aimed at higher-density livestock farms to ensure the appropriate application of manure nutrients (Act 38 of 2005). The law defines the regulated community as those animal facilities that are high density with more than 2,000 pounds of live animal weight per acre on land suitable for manure application. These operations are defined as concentrated animal operations (CAOs) under the law. The law includes all livestock, whether they are for production or recreation. For example, 12 horses (each weighing an average of 1,000 pounds) on 5 acres of land is a regulated farm ( $12,000 \text{ pounds of animals} \div 5 \text{ acres} = 2,400 \text{ pounds per acre}$ ). These plans must be developed by a certified specialist.

Be aware that many suburban horse farms are considered high-density livestock farms, according to the Nutrient Management Act guidelines, since they have more than 2,000 pounds of animal weight per acre. Additional details about Pennsylvania's Nutrient Management Act is available from [panutrientmgmt.cas.psu.edu](http://panutrientmgmt.cas.psu.edu) and "Agronomy Facts 54" (see Additional Resources).

## Have a Plan

It is recommended that managers of large stables (10 or more horses) prepare a written Manure Management Plan. This is a useful tool for the operator and shows that a proactive stance has been taken if methods of manure handling are questioned. Keep it simple, but address exactly

how and where manure is stored and disposed. Address leachate management and manure storage siting for reducing water pollution. Address water run-on and run-off from the stable and storage site. Even preparing a simple handwritten plan is beneficial in thinking through how to efficiently handle tons of manure and soiled bedding.

## Summary

Making manure management a more thoughtful and efficient chore benefits both the horse owner and their neighbors. Time spent planning for proper and easy manure disposal will pay back in many more hours spent enjoying the horses through decreased time and effort in stall cleaning and manure disposal chores. Maintaining good neighbor relations through fly and odor minimization will ensure the compatibility of horse stables within the neighborhood.

## Additional Resources

"Agronomy Facts 54: Pennsylvania's Nutrient Management Act (Act 38): Who Is Affected?" 2007. D. Beegle. Penn State Cooperative Extension, University Park, PA.

*Livestock Waste Facilities Handbook.* MWPS-18. 1985. 2nd edition. Midwest Plan Service. Iowa State University, Ames, IA 50011. Phone: 515-294-4337. <https://www-mwps.sws.iastate.edu>.

*On-Farm Composting Handbook.* NRAES-54. 1992. R. Rynk, editor. Natural Resources, Agriculture and Engineering Service, 152 Riley-Robb Hall, Ithaca, NY 14853-5701. 607-255-7654. [palspublishing.cals.cornell.edu](http://palspublishing.cals.cornell.edu).

*Pest Management Recommendations for Horses.* 2010. P. Daufman, D. Rutz, and C. Pitts. Penn State Cooperative Extension and Cornell University. University Park, PA.

Department of Agricultural and Biological Engineering  
246 Agricultural Engineering Building  
University Park, PA 16802  
814-865-7685, Fax: 814-863-1031  
[abe.psu.edu](http://abe.psu.edu)

## Acknowledgments

The authors would like to thank the following experts in manure management and equine sciences for their outstanding technical advice offered during review of this manuscript:

Robert Graves, professor of agricultural and biological engineering; Patricia Comerford, instructor in dairy and animal science; Timothy Murphy, conservation engineer, Natural Resources Conservation Service, Pennsylvania; and Daniel Greig, district manager, Chester County (PA) Conservation District.

Prepared by Eileen E. Fabian (Wheeler), professor of agricultural and biological engineering, and Jennifer Smith Zajackowski, senior research technologist in agricultural and biological engineering.

---

## **extension.psu.edu**

Penn State College of Agricultural Sciences research and extension programs are funded in part by Pennsylvania counties, the Commonwealth of Pennsylvania, and the U.S. Department of Agriculture.

Where trade names appear, no discrimination is intended, and no endorsement by Penn State Extension is implied.

This publication is available in alternative media on request.

The University is committed to equal access to programs, facilities, admission and employment for all persons. It is the policy of the University to maintain an environment free of harassment and free of discrimination against any person because of age, race, color, ancestry, national origin, religion, creed, service in the uniformed services (as defined in state and federal law), veteran status, sex, sexual orientation, marital or family status, pregnancy, pregnancy-related conditions, physical or mental disability, gender, perceived gender, gender identity, genetic information or political ideas.

Discriminatory conduct and harassment, as well as sexual misconduct and relationship violence, violates the dignity of individuals, impedes the realization of the University's educational mission, and will not be tolerated. Direct all inquiries regarding the nondiscrimination policy to the Affirmative Action Office, The Pennsylvania State University, 328 Boucke Building, University Park, PA 16802-5901, Email: [aao@psu.edu](mailto:aao@psu.edu), Tel (814) 863-0471.

© The Pennsylvania State University 2019

Produced by Ag Communications and Marketing

**Code UB035** 09/19pod